

3RD P^{OWER}

2023 SPRING CATALOG

INTRODUCTION

My name is Dylana Nova Scott, the “amp artist”. As a 3x patented inventor and CEO for 3RD POWER, I bring to the table a wealth of experience as a successful business person, musician and recording engineer.

My career at the manufacturing level includes Xwire, Sennheiser, X2 Digital Wireless, Line 6 and more. As a musician, I’ve had record deals on Island and Geffen and toured the world. In the studio, I’ve worked with notable producers such as Dennis Mackay and Danny Bernini.

Dylana Nova Scott, Amp Artist & CEO



What sets 3RD POWER apart?

Our hand-made tube amplifiers are the ultimate open canvas for musical expression. We specialize in refined American and British guitar tones. We are constantly evolving and improving our products and processes to ensure the best experience possible.

For our customers, my 30+ years in the industry have taught me to delight our stakeholders in every way possible. This commitment to excellence is not only reflected in our products, but also in our high moral standard in who we are and how we conduct business.

TECHNOLOGY SPOTLIGHT: HYBRIDMASTER™

HybridMASTER™



“...I didn’t need an engineering degree to decree it the best master volume I have encountered.”

Guitar Player Magazine, September 2013

The benefits of this patented design element allows users to control precise volume level adjustment all the way down to “zero” output without changing your tone. HybridMASTER is featured on virtually every one of our tube amplifiers.

SPOTLIGHT: HAND WIRED TURRET BOARD CONSTRUCTION

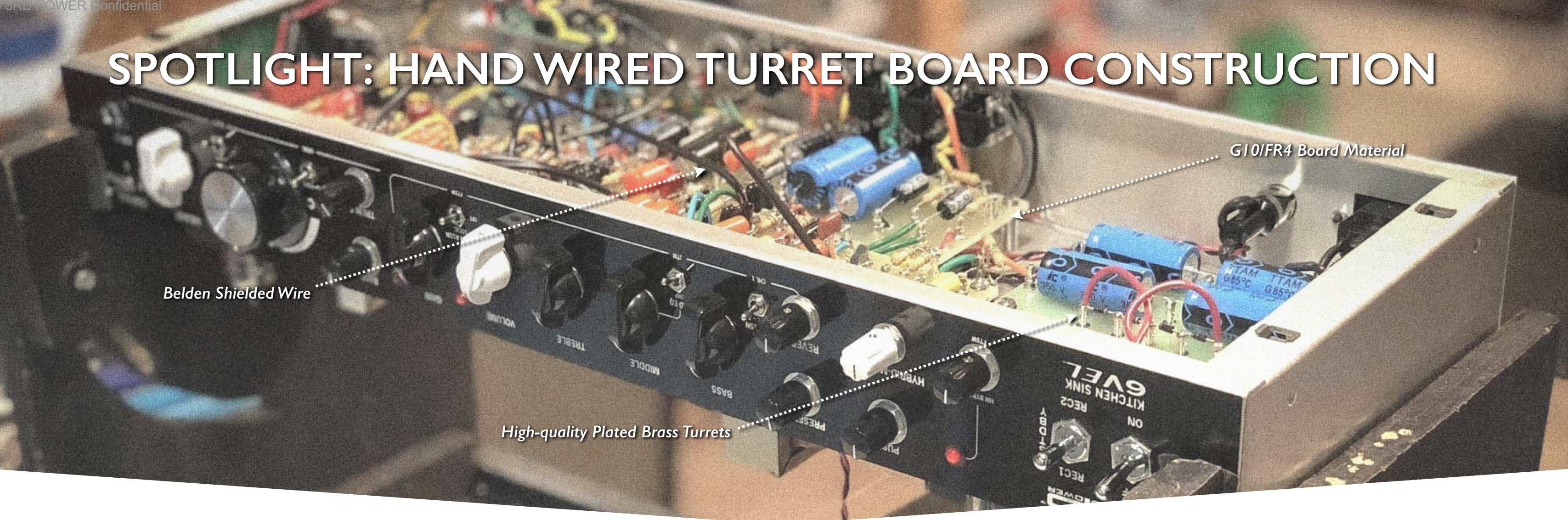

Notable modern builders have gone on record saying that printed circuit boards are just as good, if not better, than point-to-point hand-wired and even turret board construction. *WE DISAGREE* and have built our entire existence dependent upon the human touch. As a result, our amplifiers transcend the medium and elevate the art, craft, inspiration and musical expression - *IT'S NOT EVEN CLOSE!*

Every amplifier we make is built by hand in Nashville, TN USA. Each unit features point-to-point (PTP) turret board construction on military-grade G10/FR4 flame-proof board material. We custom drill, pick and place each turret prior to hand-soldering every single wire trace and jumper lead. Top-shelf components, custom transformers, as well as folded and welded aluminum chassis round out each unit.

Backed by our limited lifetime warranty, our 6-Sigma inspired lean-manufacturing process ensures high reliability and consistency in everything we make.

2023 SPRING PRODUCT LINE

THE FLAGSHIP: KITCHEN SINK 6VEL



FEATURES:

- CH.1 Fully Blendable American (Blk/Brn), AC or AC Top Boost Voices
- CH.2 (dirty) Faithful Vintage 60's to Hot-rodged Plexi Tones
- Preamp Gain Boost on CH.2 (Foot-switchable)
- Dual Global Amp Volume Presets (Foot-switchable)
- Hybrid-Master For Flawless Tube Tone at the Perfect Volume
- Hand-built PTP on Turret Boards in Nashville, TN
- American-made Transformers Throughout
- Pedal Compatible All Tube FX Loop
- Studio-quality Tube Driven Spring Reverb
- 6VEL means EL34, 6L6, 6V6, 5881 Compatibility



4 Button Pro FS

212 Cabs Available



The KITCHEN SINK 6VEL is the ultimate boutique hand-wired tube guitar amplifier featuring classic 1960's point-to-point construction. It possesses the heart and soul of three legendary vintage amplifier voices (AC, American and Plexi). The clean channel offers four blendable voices: American (Blk/Brn), AC or AC Top Boost! The dirty channel gets its inspiration from the legendary 1968 Plexi Superlead and adds foot-switchable preamp gain boost so you can shift tones on the fly from sparkling Plexi clean tones, 70s rock crunch, to 80s scorching hard rock. A pedal-optimized all tube FX loop, Studio quality all tube spring reverb, 4-Button Pro Foot Switch and Hybrid-Master volume circuitry round out the features.

THE FLAGSHIP: KITCHEN SINK 6VEL (BACK PANEL)



Back Panel Features Include: Power Tube Bias Adjustment, 16, 8, 4 Ohm speaker Selector Switch, All-tube Buffered Effects Loop (assignable “always on” or placed under foot switch control), 7-Pin DIN Foot Switch Jack, HybridMaster and HM Bypass for foot switchable lead boost.

TECHNOLOGY SPOTLIGHT: TRICAB SPEAKER CHAMBER

Bass traps in the corners

Single "dead panel"

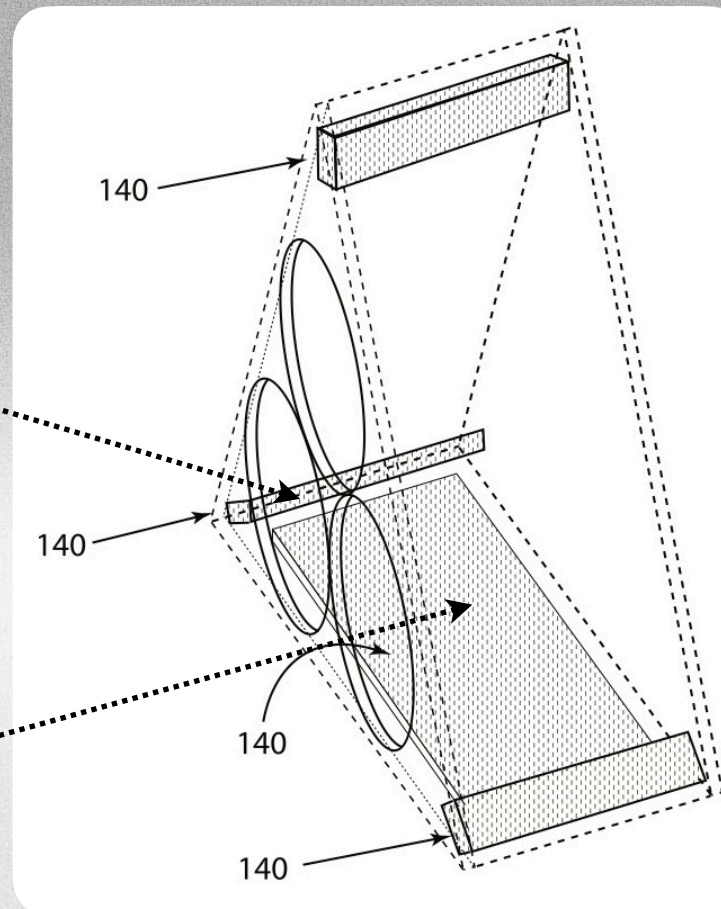

Live end

Dead end



Our DC-212 Cab features two triangular chambers with these studio-grade acoustical treatments

The benefits of this patented design element include:

- Reduced standing waves and various interference nodes due to early reflections
- Inspired by Studio Control Room design concepts
- Controlled resonance
- Delivers clear, articulate sound reproduction with wide sonic footprint

FLAGSHIP CABINET: DUAL-CHAMBERED STEREO 212



DC-212 Horizontal Format

FEATURES:

- Patented – Two internal Tri-cab™ speaker chambers eliminate standing waves
- 8-ohm Mono or 16-ohm Stereo operation
- 5/8" baltic birch enclosure construction
- Closed-back on one chamber, open-back on the other
- Horizontal & Vertical Orientation Available
- Loaded with 2x WGS Retro 30 Speakers

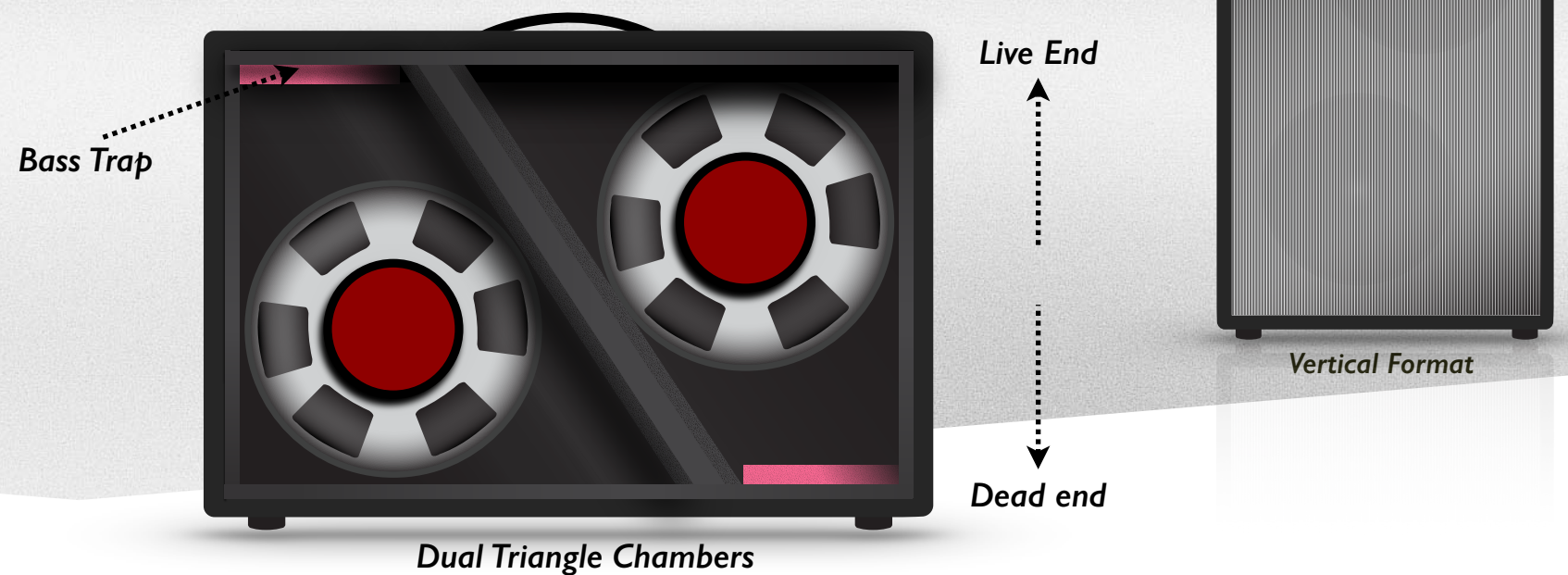

Bass Trap

Live End

Dead end

Vertical Format

Dual Triangle Chambers

The DC-212 is a dual-chambered true stereo 212 speaker cabinet designed to deliver a full-bodied frequency response that is well defined and in control throughout the frequency spectrum of your guitar tone. With its patented design, the DC-212 is the perfect choice when you want your sound to translate in the mix with authority.

WHAT IS 6VEL?

???

6VEL

???

All 3rd Power amplifier models that include the 6VEL moniker is our way of announcing that that amplifier model is designed to be compatible with a wide variety of large-base octal output power tubes. These include: EL34, 5881, 6L6, 6V6 and others. Each 6VEL equipped amplifier includes external fixed bias terminals and an adjustment screw to optimize your amp's performance for each tube type.

THE CLEAN & DIRTY SINKS

6VEL

&

MK-II

We **SPLIT** our Kitchen Sink amplifier into **TWO NEW SERIES!**

OVERVIEW: DIRTY SINK 6VEL



112 Combo

FEATURES:

- British Voiced Plexi & Cascaded Preamp Section (switchable)
- Dual-mode 3-Band EQ (JTM/JMP – switchable)
- Tube Buffered FX Loop (foot-switchable)
- Preamp Gain Boost (foot-switchable)
- Preamp Bias Selector (4 position switch from cold to warm)
- HybridMaster plus foot-switchable lead boost
- 6V6 (~20W) or 5881/EL34/6L6 (~35W and up) Operation
- Back-panel Bias Test Points and Adjustment Pot
- Over-sized /Overbuilt Power Transformer and Power Supply
- 4 Button Pro Foot Switch & 7 Pin Cable (included)
- Hand-wired and Hand Built in Nashville, TN
- Limited Lifetime Warranty



Head + Compact 112

The Ultimate British Crunch Amplifier System. The DIRTY SINK 6VEL is our new British-Crunch voiced amplifier based on the dirty channel of our flagship, Kitchen Sink 6VEL amplifier! Loaded with M6-Grade Steel transformers and an overbuilt power supply delivering 35+ watts of power in a 32 lb. grab-n-go combo. Features include a selectable Plexi/Cascade voiced British preamp, Dual Mode 3-band cathode-follower EQ (JTM/JMP), 4-way Preamp Bias Selector, Foot-switchable preamp gain boost, Foot-switchable tube buffered effects loop, Foot-switchable lead boost, our patented Hybrid-Master, external bias test terminals with back panel adjustment control, Switchable internal cooling fan, AND the ability to run 6L6, EL34, 5881 and 6V6 and more - hand built in the USA and covered by a lifetime warranty.

OVERVIEW: DIRTY SINK 6VEL (BACK PANEL)



Back Panel Features Include: Chassis Mounted Cooling Fan (switchable on/off), Power Tube Bias Adjustment, 16, 8, 4 Ohm speaker Selector Switch, All-tube Buffered Effects Loop (assignable “always on” or placed under foot switch control), 7-Pin DIN Foot Switch Jack, HybridMaster and HM Bypass for foot switchable lead boost.

OVERVIEW: DIRTY SINK 6VEL 4 BUTTON PRO FOOT SWITCH



DS4 BUTTON PRO Features Include: Active/Silent Mode (keep the stage quiet in between songs when talking to the crowd, swapping guitars, etc, + Gain for preamp gain boosts on demand, FX Loop On/Off, Solo Boost (Foot-switch Bus) for cuing solos. +Gain and FX Loop can be assigned to the FTSW BUS for single button control over lead boost with more preamp gain and effects (such as a delay unit) for perfect lead tones.

OVERVIEW: DIRTY SINK MKII



112 Combo

FEATURES:

- British Voiced Plexi with Foot Switchable +Gain
- Dual-mode 3-Band EQ (JTM/JMP – switchable)
- Tube Buffered FX Loop
- Preamp Bias Selector (2 position switch from cold to warm)
- HybridMaster (patented)
- Custom American-made Transformers
- American-made 12" WGS Green Beret Speaker
- Class AB 6V6 (~20W) Operation
- Single Button Foot Switch (included)
- Hand-wired and Hand Built in Nashville, TN
- Limited Lifetime Warranty



Head + Compact 112

The DIRTY SINK MKII is a feature-rich grab-n-go combo that operates on a pair of 6V6 for 20 Watts of power. Features include a Plexi voiced preamp, Dual Mode 3-band cathode-follower EQ (JTM/JMP), switchable Preamp Bias Selector (CLD/WRM), Foot-switchable preamp gain boost, our patented Hybrid-Master, All tube buffered FX Loop hand built in the USA and covered by a lifetime warranty.

OVERVIEW: DIRTY SINK MKII (BACK PANEL)

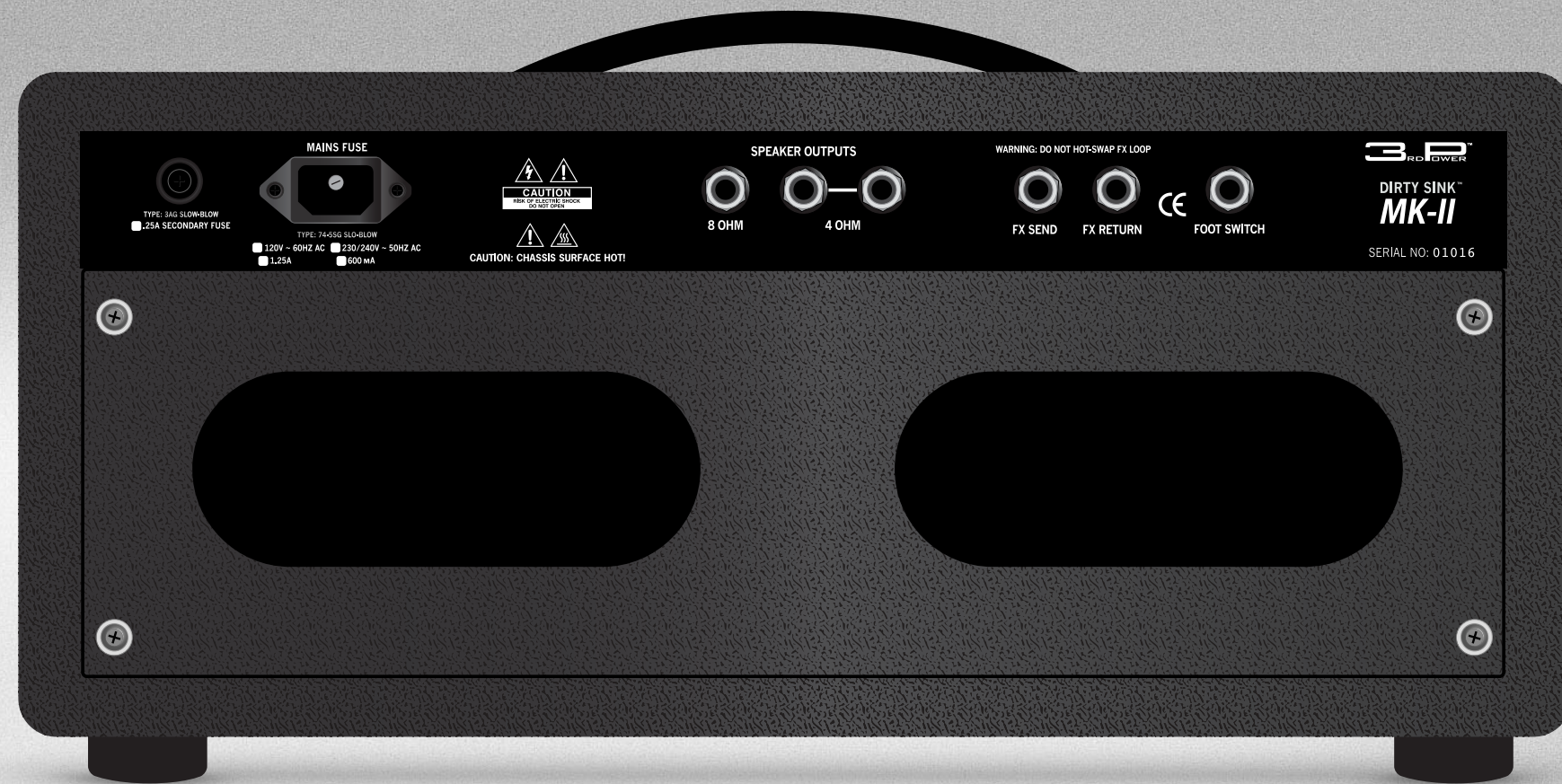

Back Panel Features Include: one 8 Ohm, and two 4 Ohm speaker output jacks, All-tube Buffered Effects Loop, 1/4" tip-sleeve Foot Switch Jack.

OVERVIEW: DIRTY SINK AMPS SIDE BY SIDE



Dirty Sink 6VEL
6L6, 6V6, 5881, EL34 and more



Dirty Sink MKII
6V6 only

Larger stages, larger backlit logo. More output tube options requires a taller head box enclosure to accommodate larger glass output tubes.

OVERVIEW: CLEAN SINK 6VEL



112 Combo

FEATURES:

- Fully Blendable American and AC Voices
- American Voice Switch (Black/Brown)
- AC Voice Switch (Normal/Top Boost)
- Dual-mode 3-Band EQ Switch (American/British)
- HybridMaster
- 6V6 (~20W) or 5881/EL34/6L6 (~35W and up) Operation
- Back-panel Bias Test Points and Adjustment Pot
- Over-sized /Overbuilt Power Transformer and Power Supply
- All-Tube Spring Reverb
- Hand-wired and Hand Built in Nashville, TN
- Limited Lifetime Warranty



Head + Compact 112

The CLEAN SINK 6VEL is our new multi-voiced amplifier based on the clean channel of our flagship, Kitchen Sink 6VEL amplifier! Loaded with M6-Grade Steel transformers and an overbuilt power supply delivering 35+ watts of power in a 32 lb. grab-n-go combo. Features include four blendable voices - American (Blk/Brn), AC or AC Top Boost, Dual Mode 3-band cathode-follower EQ (British/American), All-tube Spring Reverb, High-Frequency Damping, our patented Hybrid-Master, external bias test terminals with back panel adjustment control, Switchable internal cooling fan, AND the ability to run 6L6, EL34, 5881 and 6V6 and more - hand built in the USA and covered by a lifetime warranty.

OVERVIEW: CLEAN SINK 6VEL (BACK PANEL)

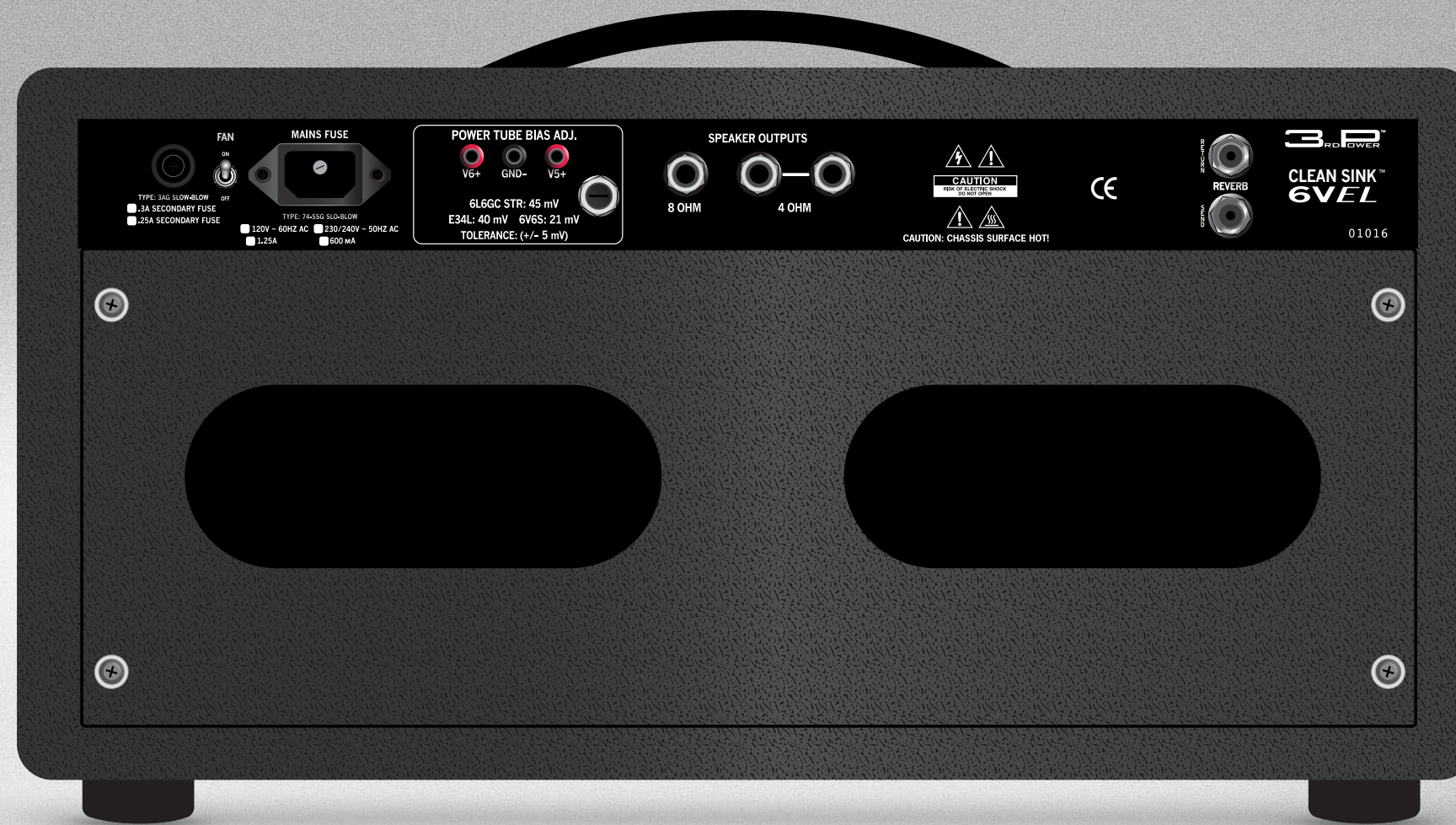

Back Panel Features Include: Chassis Mounted Cooling Fan (switchable on/off), Power Tube Bias Adjustment, one 8 Ohm, and two 4 Ohm speaker output jacks, All-tube Spring Reverb.

OVERVIEW: CLEAN SINK MKII



112 Combo

FEATURES:

- Fully Blendable American and AC Voices
- AC Voice Switch (Normal/Top Boost)
- HybridMaster
- Custom American-made Transformers
- American-made 12'' WGS Green Beret Speaker
- Class AB 6V6 (~20W) Operation
- All-Tube Spring Reverb
- Hand-wired and Hand Built in Nashville, TN
- Limited Lifetime Warranty



Head + Compact 112

In the studio and on stage, combining and layering multiple amp voices has often been one of the “tricks” the pros have used to achieve their signature sounds. Based on the clean channel of our flagship Kitchen Sink amplifier, the CLEAN SINK gives you the ability to do just that! The CLEAN SINK features three blendable voices (American, AC or AC Top Boost) that are managed by our unique Voice Pan control. Pan hard left and you have American tones, hard right and you have AC tones, anywhere in between and you’re creating your own signature blend of multiple-voiced tonal goodness. Our all-tube spring reverb, Hybrid-Master and High Frequency Damping round out the features of this superb 112 combo.

OVERVIEW: CLEAN SINK MKII (BACK PANEL)



Back Panel Features Include: one 8 Ohm, and two 4 Ohm speaker output jacks, reverb jacks.

OVERVIEW: CLEAN SINK AMPS SIDE BY SIDE



*Clean Sink 6VEL
6L6, 6V6, 5881, EL34 and more*



*Clean Sink MKII
6V6 only*

Larger stages, larger backlit logo. More output tube options requires a taller head box enclosure to accommodate larger glass output tubes.

DESIGN SPOTLIGHT: SIZE DOES INDEED MATTER

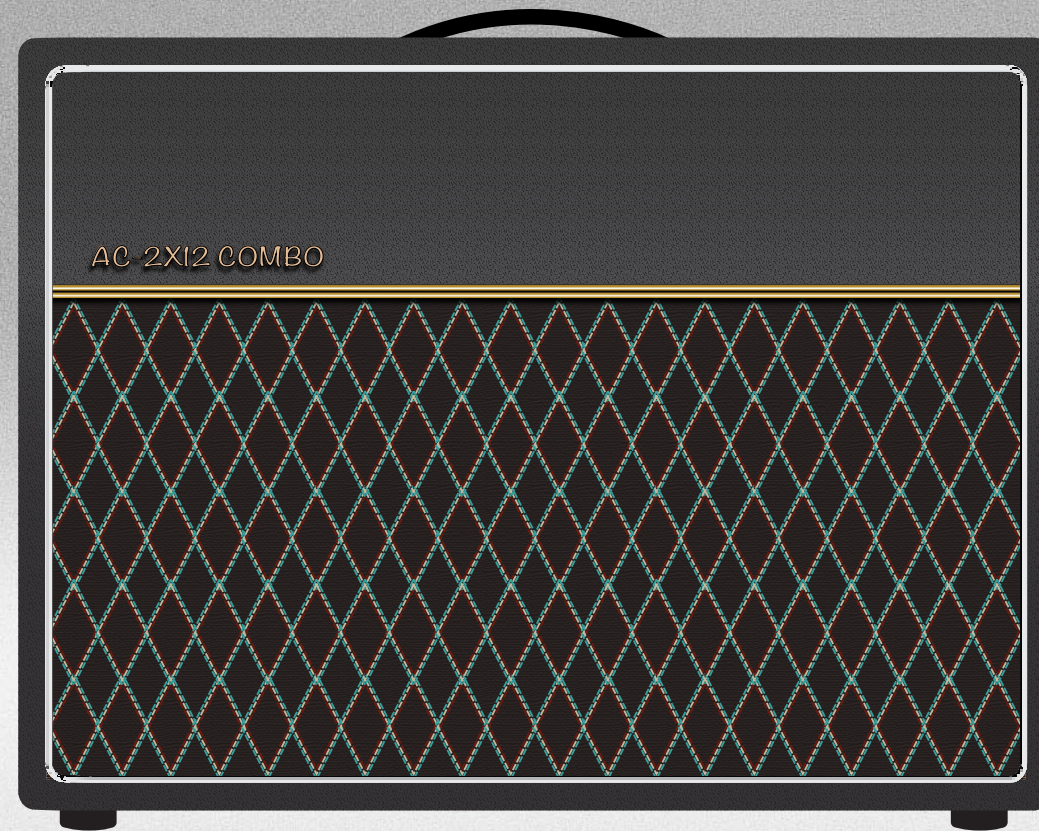

Weight: 71lbs.
Dims: 27.64" x 10.43" x 21.89"

Weight: 33lbs.
Dims: 19-7/8 in. x 16 in. x 9.5 in

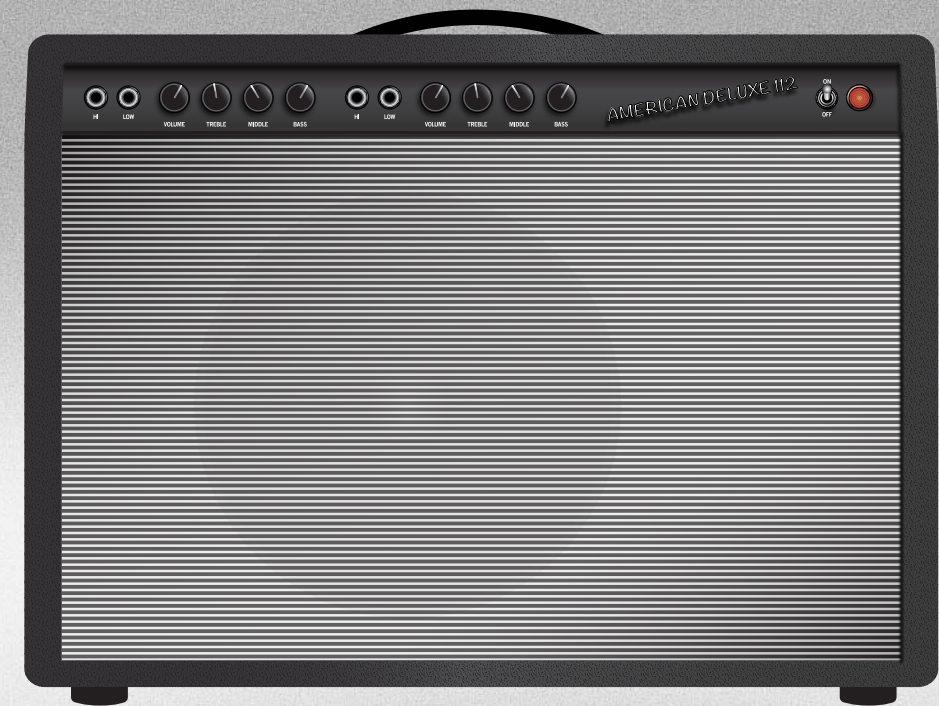

Weight: 42lbs.
Dims: 24.5" x 9.5" x 17.5"

While our quest for the ultimate tone originated with high-powered amplifiers and large-format speaker cabs, we've been refining our compact 112 combo enclosure for the past 7 years. We've tried various woods, joinery styles, baffle materials, thicknesses, enclosure depths, back panel sizes and other variable attributes.

At this point, we've made close to 1,000 units and pretty much perfected the performance. Because of this, we've invested the past two years redesigning all of our Dirty/Clean/Spanky series amplifiers to utilize this same chassis/enclosure format. It hasn't been easy but we're extremely excited to finally bring these wonderful amps to market.

OVERVIEW: WOOLY COATS EXTRA SPANKY 6VEL



112 Combo

FEATURES:

- Clean, American Voiced, High Headroom Preamp Section
- 3-Band EQ with Two Voices per Band
- Tube Buffered FX Loop
- Tube Driven Spring Reverb with Dual Mode Switch
- Unique High Frequency Damping Circuit
- 6V6 (20W) or 6L6 (35W) Operation
- Back-panel Bias Test Points and Adjustment Pot
- Over-sized and Overbuilt Power Transformer and Power Supply
- Hand-wired and Hand Built in Nashville, TN
- Limited Lifetime Warranty



Head + Compact 112

Crafting your tone can't get any easier. The front panel controls deliver a wide variety of tonal options instantly at your fingertips. The on-board three band EQ features two modes per band making it a snap to optimize tones sourced directly from guitars loaded with a variety of pickups as well as a master pedal-board amp/reinforcement solution.

OVERVIEW: EXTRA SPANKY 6VEL (BACK PANEL)



Back Panel Features Include: Power Tube Bias Adjustment, one 8 Ohm, and two 4 Ohm speaker output jacks, Tube Buffered FX Loop, All-tube Spring Reverb.

OVERVIEW: WOOLY COATS SPANKY MKII+



112 Combo

FEATURES:

- Clean, American Voiced, Preamp Section
- 3-Band EQ with Bypass Switch (Boost Mode)
- Tube Driven Spring Reverb
- 6V6 (20W) Class-AB Operation
- Premium American-made Heyboer Transformers throughout
- Premium American-made 12" WGS ET-65 Speaker
- Patented HybridMASTER volume management technology
- Unique Treble Damping circuit
- 8 ohm and 4 ohm speaker jacks
- Choke filtered power supply
- Limited Lifetime Warranty



Head + Compact 112

The Spanky MKII+ is a classic mid-60's American styled amplifier with an exclusive midrange frequency control and an over-built power supply to deliver throwback tone with extra headroom and punch (it's an insane pedal-platform amp). Accommodating most any guitar you plug in, the SPANKY MKII's midrange control really sets this amp apart from the pack. Set the mid control around 10 o'clock, you're in classic Blackface territory. Push the mids past noon, you're entering Tweed Land with an excellent midrange growl. Rounding out the features are 3rd Power's patented Hybrid-MASTER volume technology along with our studio-grade all-tube large pan Spring Reverb. And when you want American-flavored grit, there's a new front panel switchable boost mode to take it to the edge of breakup or all the way over the top!

OVERVIEW: SPANKY MKII+ (BACK PANEL)



Back Panel Features Include: One 8 Ohm, and two 4 Ohm speaker output jacks, All-tube Spring Reverb.

OVERVIEW: EXTRA SPANKY 6VEL, SPANKY MKII+ SIDE BY SIDE



Extra Spanky 6VEL
6L6, 6V6, 5881, EL34 and more



Spanky MKII+
6V6 only

Larger stages, more output tube options requires a taller head box enclosure to accommodate larger glass output tubes.

OVERVIEW: WOOLY COATS SPANKY JR



110 Combo

FEATURES:

- Clean, American Voiced, High Headroom Preamp Section
- 3-Band EQ with Bypass Switch (Boost Mode)
- Tube Driven Spring Reverb
- 6V6 (5W) Class-A Operation (standard)
- Compatible with 6L6, EL34, 5881, KT66 and more
- 5Y3 Tube Rectified
- (1x) 8 Ohm, (2x) 4 Ohm Output Jacks
- Cathode Biased for plug-n-play Octal-based Tube Swapping
- Overbuilt Power Transformer and Power Supply
- Hand-wired and Hand Built in Nashville, TN
- Limited Lifetime Warranty

The SPANKY Jr 6VEL is our new high-headroom grab-n-go 5 Watt 110 combo amplifier! Thanks to 3P's 6VEL™ technology, you can operate the amp on most of your favorite tube combinations. The SPANKY Jr 6VEL is for virtually everyone and is at home just about anywhere. It's designed on an overbuilt power supply including the exact higher current power transformer as used in our 20W Spanky MKII+ so you know its got enough headroom and punch for any low volume gig, rehearsal, showcase, or any environment where inspiration calls. We've also incorporated the Spanky MKII+'s switchable boost mode to take it to the edge of breakup or all the way over the top!

OVERVIEW: SPANKY JR (BACK PANEL)



*Spanky Jr 6VEL
6L6, 6V6, 5881, EL34, KT66 and more*

Back Panel Features Include: One 8 Ohm, and two 4 Ohm speaker output jacks, All-tube Spring Reverb.

OVERVIEW: COMPACT 112



Compact 112

FEATURES:

- Solid 3/4" Pine Outer Shell Construction
- 8-ohm Mono Standard Operation
- 1/2" birch Front and Back Baffles
- Horizontal & Vertical Orientation Available
- Loaded with Select WGS 12" Speakers

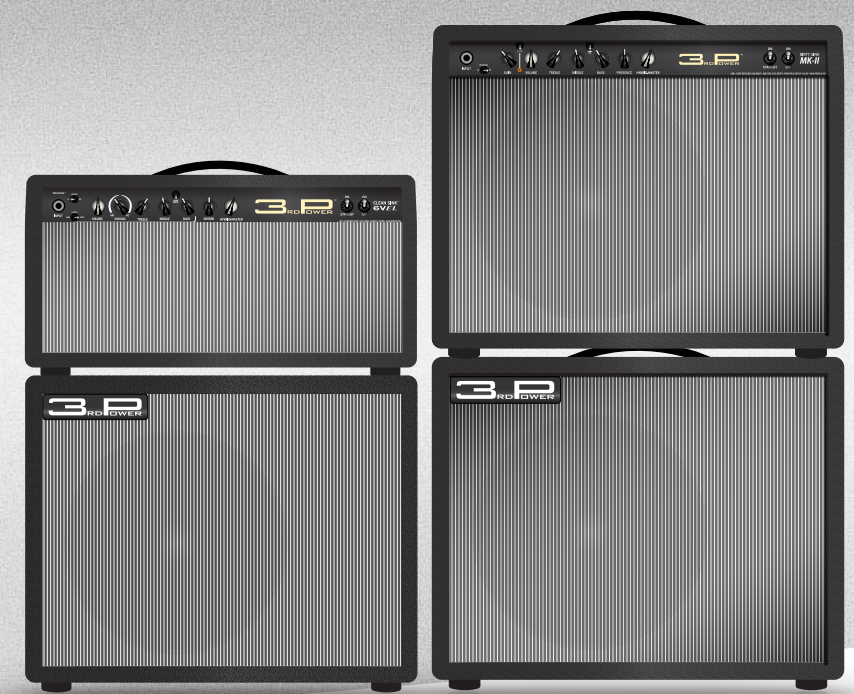
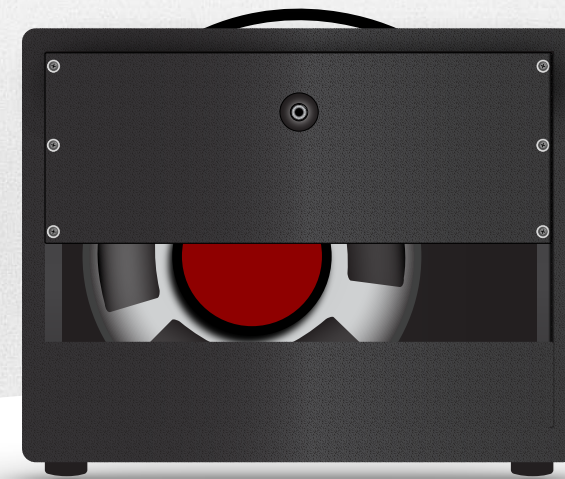

Head & 1/2 Stack

Piggy-back 1/2 Stack

The Compact 112 is a mono speaker cabinet designed to deliver a full-bodied frequency response that is well defined and in control throughout the frequency spectrum of your guitar tone. The Compact 112 pairs with any of our 20W to 35W combos and heads and is the perfect choice when you want your sound to translate in the mix with authority.

OVERVIEW: LOVE DRIVE PEDAL



FEATURES:

- Preamp/Clean Boost/Overdrive Pedal
- Wave-shaping 3-Band EQ
- Top Mounted Input/Output and Power Connections
- Soft-touch, Silent “No Click” True-bypass Switching
- Buffered Input and Output When Active
- Through-hole Amp Grade Components
- Hand Built in Nashville, TN
- Built Like a Tank, Limited Lifetime Warranty



*Hand-built,
Through-hole Construction*

The LOVE DRIVE can serve as the first or last slot (or anywhere in between) on your pedal board. When on, the LOVE DRIVE features buffered input and output circuitry. The input buffer ensures your signal will enter the FET circuitry under optimal conditions. This ensures that the two gain stages and 3-band EQ will sound their absolute best. The output buffer means the LOVE DRIVE will drive longer cable runs while keeping your tone intact. When cascading drive one into the other, the dual buffer stages of the LOVE DRIVE will ensure that your tone soars without collapsing into itself due to mismatches in circuitry. This will be especially appreciated when you cascade a LOVE DRIVE with fuzz-style pedals.

TECHNOLOGY SPOTLIGHT: MAGFRAG GUITAR PICKUPS

REGULAR

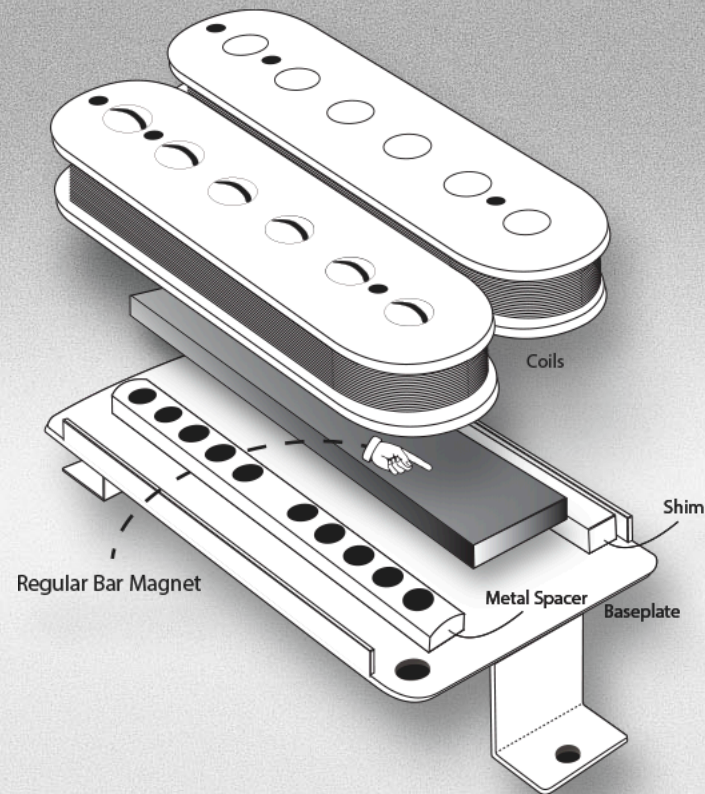

REGULAR DESIGN

VS.

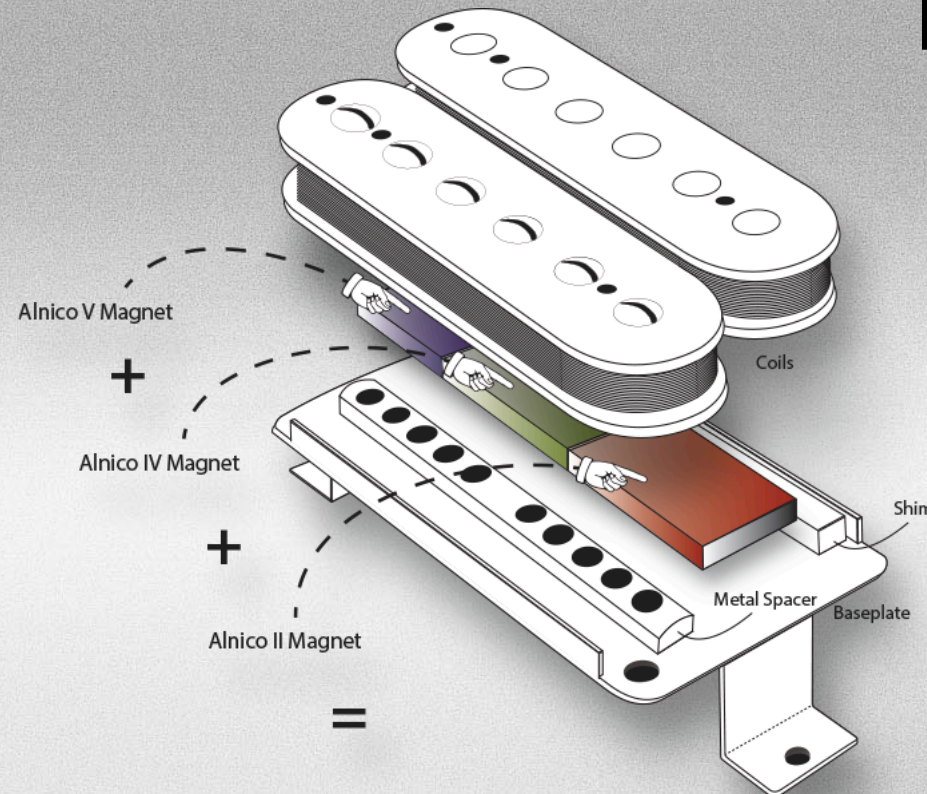

MAGFRAG DESIGN

Proudly made in the USA, MAGFRAG pickups represent a modern update on the classic PAF humbucker of the 1950s. MAGFRAGS are a dual coil, three-magnet (rather than a typical single bar magnet) electric guitar pickup with superb clarity, detail and warmth for a stunningly direct sound with breathtaking realism.

Multi-magnet construction, Alnico II (1st and 2nd strings), Alnico IV (3rd and 4th strings), and Alnico V (5th and 6th strings), and Four Conductor wiring make MAGFRAG pickups exceptionally flexible. MAGFRAG pickups capture anything from a tickle on the strings to roaring shred without unwanted muck or undesired coloring to your sound.

OVERVIEW: MAGFRAG PICKUPS



There are four humbucking MagFRAG pickup models available. Full details are available at 3rdpower.com/magfrag-humbuckers/

We also make MagFRAG single coil pickups with a similar approach. More information is available here: 3rdpower.com/magfrag-s-type/

OVERVIEW: DIGITAL KEMPER PROFILER AMP PACK

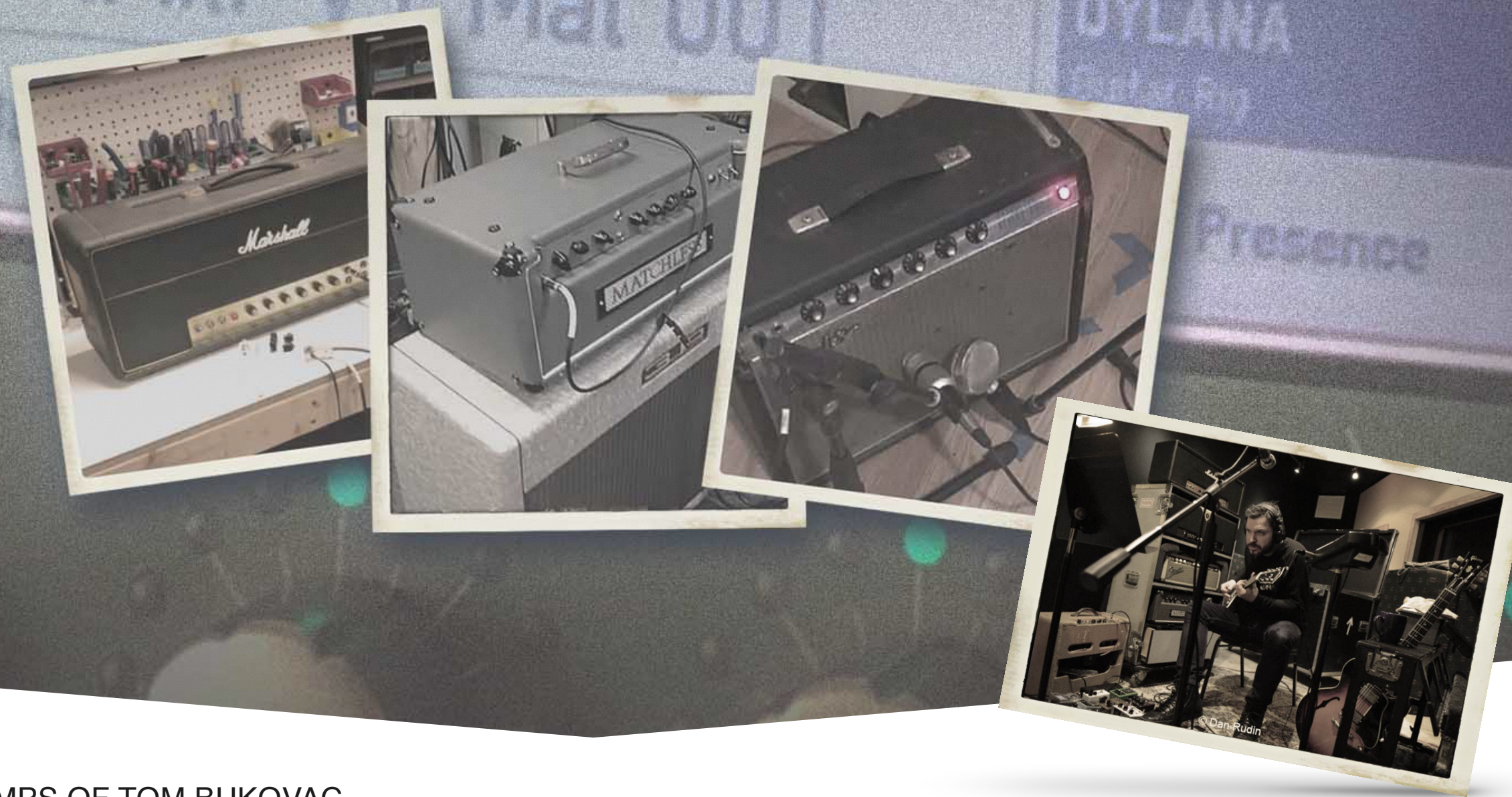

HITMAKERS:™ VOL. I THE AMPS OF TOM BUKOVAC

3RD POWER collaborated with Tom Bukovac to bring his amp collection to the Kemper Profiler platform. With 70+ studio-quality amp rigs profiled from the hit-maker amp collection of guitarist, Tom Bukovac, the Hit Makers: Vol. I amp pack is a deep-dive into the rich, vintage amp collection used by Tom Bukovac on over 500+ albums.

More information at: 3rdpower.com/hitmakers-volume-one-profile-pack/

IN THE STUDIO: DANN HUFF



“For what I do, the 3RD POWER difference is how high-quality the tone is and then how BIG the sweet spot is... I simply cannot get a bad sound from your amps!”

Dann Huff, Guitarist/Producer, (Keith Urban, Rascal Flatts, Hunter Hayes)

IN THE STUDIO: DANN HUFF

ON STAGE: LENNY KRAVITZ



“I never thought I would give up the classic 4x12 but the 3RD POWER cabinets are exceptional.”

Lenny Kravitz

ON STAGE: LENNY KRAVITZ

IN THE WILD

QUINTON GIBSON



Nashville session guitarist, on tour with Darius Rucker

ELIOT IVES



On tour with Justin Timberlake

PHIL HUGHLEY



Nashville songwriter/guitarist Future Vintage Playlist

IN THE WILD

IN THE WILD

JAMES MITCHELL



Nashville session guitarist, on tour with Alison Krauss

BOO MASSEY



Nashville session guitarist, on tour with Miranda Lambert

SOL PHILCOX-LITTLEFIELD



Nashville session guitarist

IN THE WILD

3_{RD} P_{OWER}

Thank You!