

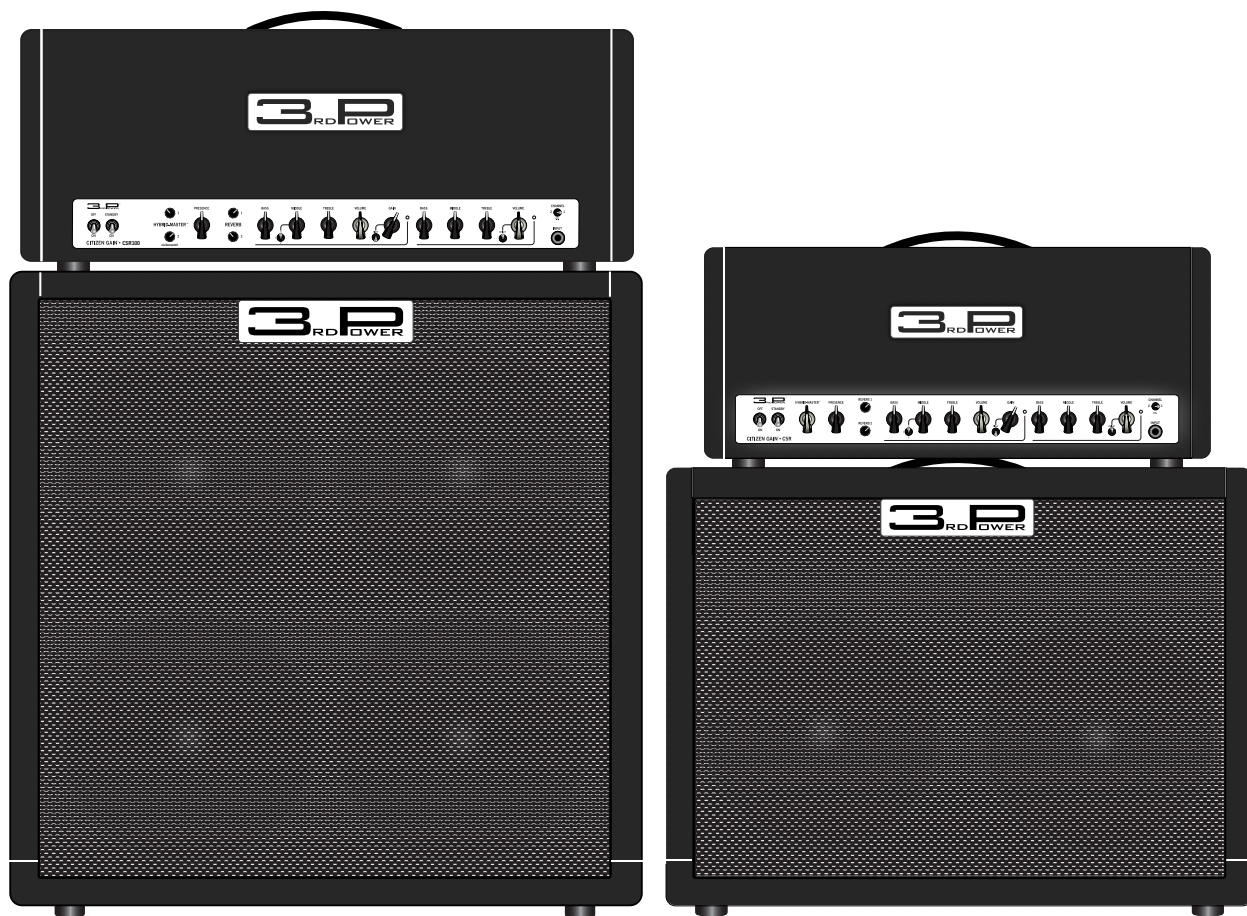

CITIZEN GAIN • CSR100™

CITIZEN GAIN • CSR™



G U I T A R A M P L I F I E R

U S E R ' S G U I D E

Your 3RD POWER Amplifier is a professional musical instrument amplifier. The information contained herein is current at the time of publication. However, specifications are subject to change without prior notice.

PRECAUTIONS & WARNINGS

- **READ THESE INSTRUCTIONS.**
- **KEEP THESE INSTRUCTIONS.**
- **HEED ALL WARNINGS.**
- **FOLLOW ALL INSTRUCTIONS.**
- **YOUR AMPLIFIER IS LOUD!
EXPOSURE TO HIGH SOUND VOLUMES MAY CAUSE PERMANENT HEARING DAMAGE !
Practice "safe listening."**
- **No user serviceable parts inside. Refer service to qualified personnel. Always unplug AC power before removing chassis.**
- **IF YOU INTEND ON OPERATING THIS EQUIPMENT OUTSIDE OF THE USA: Always insure that unit is wired for proper voltage. Make certain all connections and grounding conforms with local standards. Make certain that you have obtained authorization to operate prior to connecting to power supply.**
- **WARNING: Vacuum tube amplifiers generate heat. To insure proper ventilation always make certain there is at least four inches (100mm) of space behind the rear of the amplifier cabinet.**
- **Keep away from curtains or any flammable objects.**
- **WARNING: Do not block any ventilation openings on the rear or top of the amplifier. Do not impede ventilation by placing objects on top of the amplifier which extend past the rear edge of its cabinet.**
- **WARNING: Do not expose the amplifier to rain, moisture, dripping or splashing water. Do not place objects filled with liquids on or nearby the amplifier.**
- **WARNING: Always make certain proper load is connected before operating the amplifier. Failure to do so could pose a shock hazard and may result in damage to the amplifier.**
- **Do not expose amplifier to direct sunlight or extremely high temperatures.**
- **Always insure that amplifier is properly grounded. Always unplug AC power cord before changing fuse or any tubes. When replacing fuse, use only same type and rating.**
- **Avoid direct contact with heated tubes. Keep amplifier away from children.**
- **Be sure to connect to an AC power supply that meets the power supply specifications listed on the rear of the unit. Remove the power plug from the AC mains socket if the unit is to be stored for an extended period of time. If there is any danger of lightning occurring nearby, remove the power plug from the wall socket in advance.**
- **To avoid damaging your speakers and other music equipment, turn off the power of all related equipment before making the connections.**
- **Do not use excessive force in handling control buttons, switches and controls. Do not use solvents such as benzene or paint thinner to clean the unit. Wipe off the exterior with soft cloth.**



Special Features of the Citizen GAIN CSR100™:

- Hand-made in the USA
- Point-to-point turret board construction
- Cascaded Gain Stage tube preamp
- Selectable clipping-diode mode with additional saturation (Tight Response)
- Controls include Gain, Volume, Treble, Middle, Bass, Reverb
- Full-range tone stack features 3 EQ curves (JTM45, '68 Superlead, Modern)
- Studio-quality Accutronics spring reverb w/ independent level control per channel
- Patented HybridMASTER™ volume control
- Citizen Loop - tube buffered FX loop optimized for use with pedal devices
- Custom made two-button foot switch with 7-pin DIN cable
- Presence control
- Illuminating backlit logo
- 4 x EL34 power tubes, up to 100W (variable down to 1W with HybridMASTER)
- 16, 8 and 4 ohm speaker outputs

Special Features of the Citizen GAIN CSR™:

- As above with the following specs...
- 2 x EL34 power tubes, up to 40W (variable down to 1W with HybridMASTER)
- 16, 8 and 4 ohm speaker outputs

Dual Foot-switchable HybridMASTER Controls (CSR100 Version ONLY)

Create custom volume level presets perfect for setting up a rhythm and lead volume scene changes and recalling them via foot-switch. This feature is only available on the CSR100.

Dimensions & Weights:

Subject to change anytime. Please measure your amp carefully if a custom case is being made. These measurements do not include handle and rubber feet.

CSR100 Version: Dimensions (WxHxD): 29 x 8.0 x 9.33 in.

Weight: 43.5 lb.

CSR Version: Dimensions (WxHxD): 24 x 10.5 x 9.33 in.

Weight: 29.5 lb.

Front Panel:

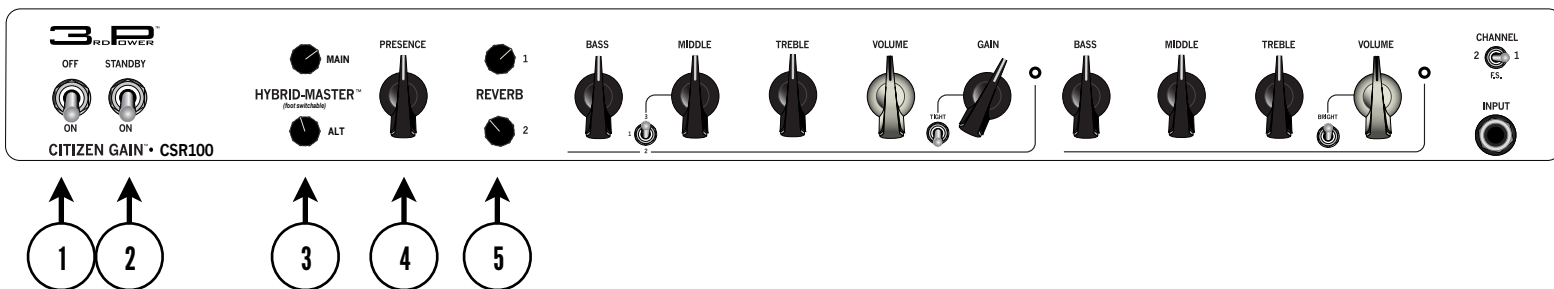

Preparing to Operate your Citizen Gain CSR™

Make certain that all connections are made prior to operating your Citizen Gain Amplifier including power cable, speaker connection, instrument cable and instrument connection. Make certain that all tubes are installed.

Power Switch (1)

The POWER switch, when placed in the DOWN position, provides AC wall power to the amplifier.

Standby Switch (2)

The STANDBY switch, when placed in the UP position, puts the amplifier in 'standby mode' allowing the tubes to warm up. When this switch is placed in the DOWN position, the tube circuitry is fully functional and ready to amplify your guitar signal.

Dual HybridMASTER™ Controls (3)

(CSR100 ONLY) The MAIN control is always active and sets the absolute volume ceiling. The ALT control subtracts from MAIN. To create a rhythm and lead volume scenario, try setting MAIN at 12 noon (roughly 55W) and then set ALT at 1 o'clock (roughly 28W). When toggling between ALT and MAIN, rhythm and lead volume levels will be achieved. HybridMASTER is a patented technology by 3rd Power.

Presence Control (4)

The global PRESENCE control affects both channels and allows you to adjust the character or 'forwardness' of your sound. Low settings create 'darker' tones, whereas higher settings create a 'brilliant' or crisp sound.

Dual Reverb Controls (5)

Reverb 1 sets the level of ambience when playing through the clean channel. Reverb 2 sets the level of ambience when playing through the gain channel.

Front Panel: Channel Selection

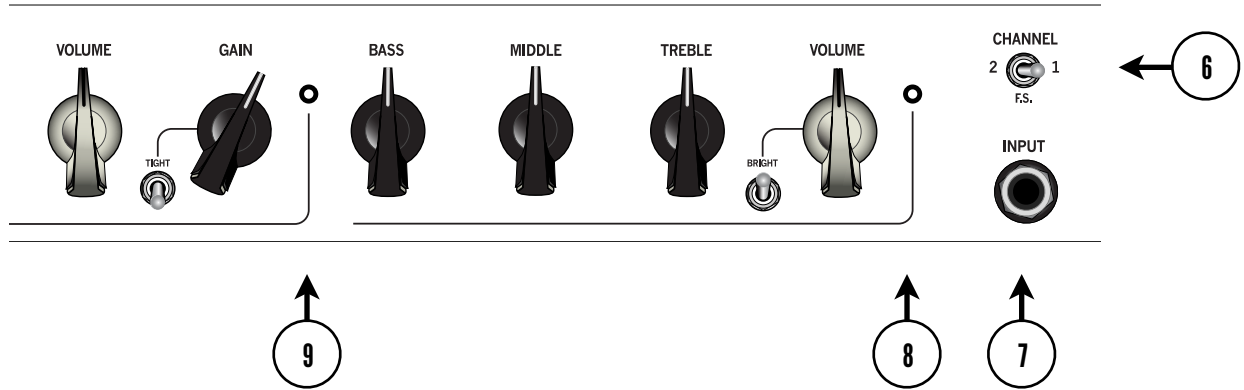

Channel Selector Switch (6)

The 3 position channel selector switch lets you select either AMERICAN or HIGHER GAIN channel modules. When set in the middle position, the amplifier becomes remote foot switchable (channel switching).

Input Jack (7)

The INPUT jack is where you connect instrument level signals.

Channel Indicator Light (8)

When selecting the American Clean channel, this backlit LED will glow a bright white color indicating that you have selected the American Clean channel for operation.

Channel Indicator Light (9)

When selecting the Higher Gain channel, this backlit LED will glow a bright amber color indicating that you have selected the Higher Gain channel for operation.

Front Panel: American Clean Channel

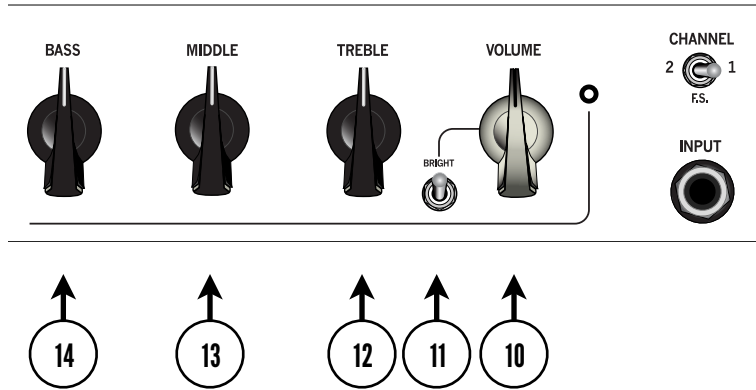

Volume Control (10)

The VOLUME control allows you to adjust the signal level as well as the temperament and overall character of your instrument's sound.

Bright Switch (11)

The BRIGHT SWITCH is a new take on enhancing the higher frequencies of your guitar. Guitarists often utilize electric guitars with electronics that are optimized for higher gain and solo tones. This includes guitars outfitted with humbucking or higher output pickups. As is often the case, these guitars sound fantastic on crunch and lead tones but typically lack the clarity and sparkle of lower output and single coil pickups. This new circuit addresses the problem by adjusting the preamp gain structure and frequency response to help you pull out superb clarity and “chime” from your otherwise “hotter” sounding instrument. Set this switch in the upward setting when using hotter instruments. For an excellent vintage American clean, set this switch in the downward position.

Treble Control (12)

The TREBLE control allows you to adjust the character of the higher frequency range.

Middle Control (13)

The MIDDLE control allows you to adjust the emphasis of the mid-range frequencies. Lower settings (between 7 and 10 o'clock) will approximate Blackface American tones. Taking this knob past noon and you will move into a more Tweed flavored midrange response.

Bass Control (14)

The BASS control allows you to adjust the depth of your lower frequencies.

Front Panel: British Gain Channel

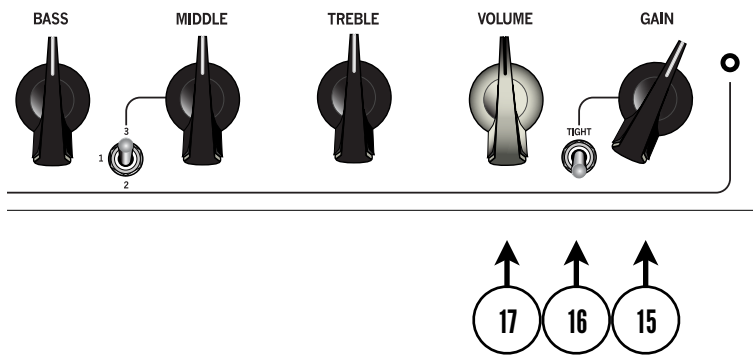

Gain Control (15)

The GAIN control allows you to adjust the signal gain level as well as the temperament and overall character of your instrument's sound. Clean tones are at the lower end of the control dial. Preamp saturation, distortion and compression increase as you go higher on the dial.

Preamp Response Switch (16)

The PREAMP RESPONSE switch allows you to adjust the response and feel of the preamp. The associated circuitry is basically switching different sets of clipping diodes in and out of the circuit. These diodes are preset to create an excellent compression effect as well as overall tightness and response. More aggressive, faster playing styles (double-picking, sweep-picking) will appreciate the Tight setting.

- THICK: All tube saturation. The tone and feel are very vintage.
- TIGHT: Adds additional channel gain and the clipping diode effect to the tone and response.

NOTE: This circuit has been enhanced to allow for clean guitar tones by simply rolling back on your guitar's volume knob.

Volume Control (17)

The VOLUME control allows you to adjust the signal level that feeds the FX Loop circuitry. When you have the GAIN control at lower settings, you will tend to run this control higher up (1 to 2 o'clock). When you have the GAIN control at higher settings, you will tend to run this control in the mid to lower setting range (10 to 11 o'clock).

Front Panel: British Gain Channel - Tone Controls

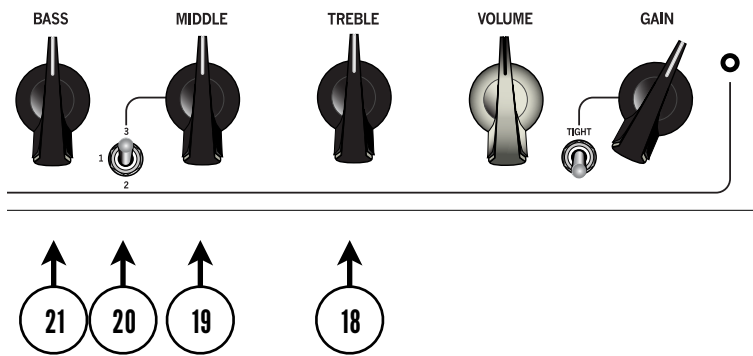

Treble Control (18)

The TREBLE control allows you to adjust the character of the higher frequency range.

Middle Control (19)

The MIDDLE control allows you to adjust the emphasis of the mid-range frequencies.

Tone Stack Selector (20)

The TONE STACK SELECTOR switch allows you to adjust the response and feel of the EQ section. The associated circuitry is selecting from different tone stack circuits to help capture the tone and feel of different rock guitar eras.

- PRESET 1: Classic 'bassman' or '65 'plexi JTM' EQ curve. The mids are scooped giving way to an exciting emphasis of low and high frequencies. This is often referenced as a "smooth" tone.
- PRESET 2: Classic '68 plexi 'superlead' EQ curve. The mids are punchy and woody with that classic growl you'd expect from this style of amplifier.
- PRESET 3: Modern higher-gain EQ curve. The pick attack has been enhanced to make aggressive playing styles slice through the mix with ease while retaining a solid kick in the low frequencies.

Bass Control (21)

The BASS control allows you to adjust the depth of your lower frequencies.

Back Panel:

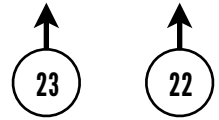
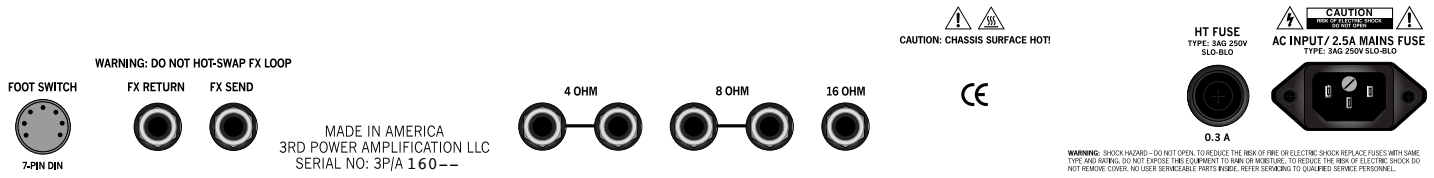

AC Fused Input (22)

The AC FUSED INPUT socket (TYPE IEC Grounded) is a required connection for operating your CITIZEN GAIN at 120V (standard USA household electrical power). The MAINS FUSE requires a 2.5 AMP slow blow fuse. This fuse protects your amplifier from voltage peaks from your power outlet.

H.T. Fuse (23)

The H.T. FUSE requires a 0.3 AMP (300 milliamp) slow-blow fuse. The H.T. FUSE usually blows if your power tubes are bad to protect the circuit from being damaged.

SAFETY NOTES:

- Always plug your amp into a properly grounded 3 prong AC outlet.
- Never plug your amp into an ungrounded outlet.
- Never remove or break off the 3rd prong safety ground pin from the power cord.
- Never use a damaged or ungrounded power cord.
- Always use the proper value and type fuse according to the rear-panel markings.
- Never attempt to replace the fuse while the amplifier is still plugged into the power source. The fuse should only be replaced when the power cord has been disconnected from its power source.

Back Panel:

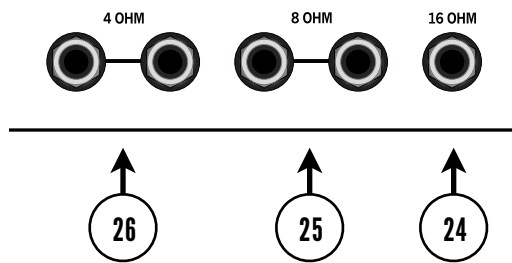

16-OHM Speaker Output (24)

The 16-OHM SPEAKER OUTPUT is provided for connecting your amplifier to standard 16 OHM speaker cabinet.

8-OHM Speaker Outputs (26)

The 8-OHM SPEAKER OUTPUTS are wired in parallel. They are provided for connecting your amplifier to a single 8-OHM speaker, or two 16-OHM speaker cabinets.

4-OHM Speaker Outputs (26)

The 8-OHM SPEAKER OUTPUTS are wired in parallel. They are provided for connecting your amplifier to a single 4-OHM speaker, or two 8-OHM speaker cabinets.

SAFETY NOTES:

- Never operate your amplifier without a connected speaker cabinet. This will damage your tubes or transformers - or both.
- Always operate your amplifier with the proper impedance output that matches your speaker cabinet(s).
- In all cases, always use a good quality heavy gauge speaker cable (not a shielded instrument cable) to connect your CITIZEN GAIN to the speaker cabinet(s).

Back Panel:

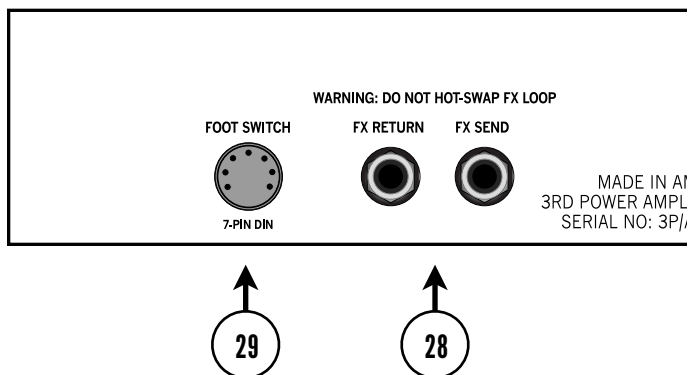

Dual Triode “Citizen Loop” Effects Loop (28)

Here's what you need to know about the CITIZEN GAIN's tube buffered series effects loop: you don't have to change the way you already configure your setup. Run your pedals up front or in the loop - it's all good!

However, should you wish to experience STUDIO QUALITY TONE from your pedals, then go ahead and run them through the loop. Seriously - try your delay, reverb, phase shifter, chorus, even your drive and compressor units through our new loop. You will likely attain a superior level of resolution and clarity that our many beta testers referred to as "more 3D."

OPERATION NOTES:

- After each channel pre-amplifies your guitar signal, they are combined and sent out of the FX SEND jack at a nominal -10dBV (just under 1V p-p) matching the levels most vintage and modern effect pedals want to see.
- The FX RETURN path brings your signal back into the amplifier with a tremendous amount of headroom (accepting signals as low as -10dBV and as high as +4dBU before the onset of compression).
- It can also be a gig-saver too. If your pedal board ever goes down during a performance, you can plug your guitar straight into the FX RETURN jack and get through a song with quality tone.

CAUTION:

Avoid “hot swap” any cables connected to the loop while the amplifier is operational. Before breaking any connections, make sure that your amp is on Standby. Failure to do so may result in a loud hum or buzz.

Channel Selector Foot-switch Jack (29)

To remotely control channel selection, connect the foot pedal with the 7-pin DIN cable (both the pedal and cable are included with purchase).

Operational Notes:

TUBE CHART for Citizen Gain CSR100

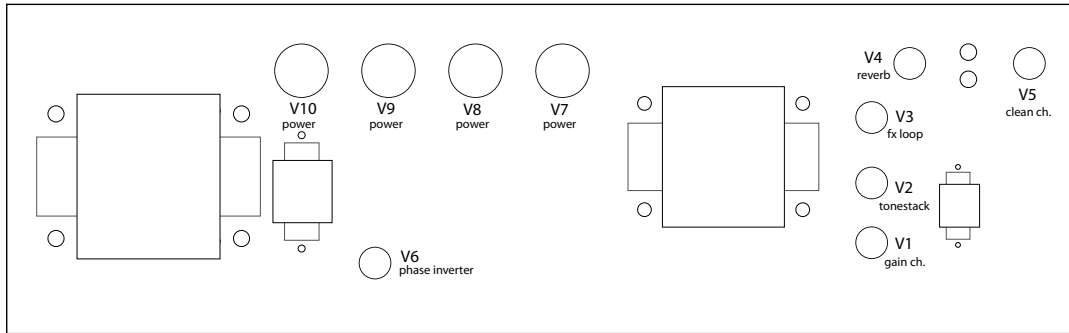

TUBE CHART for Citizen Gain CSR

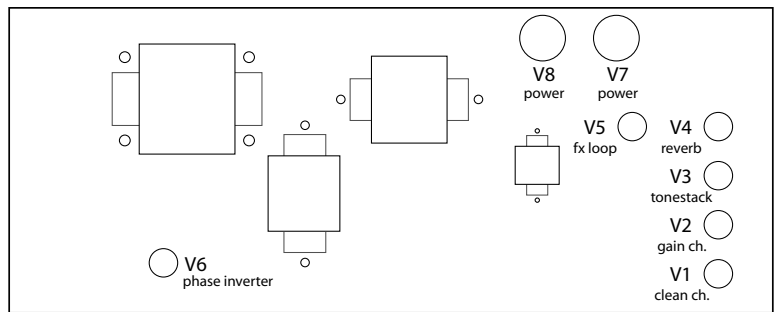

Tube Layout and Requirements:

- V1: JJ 12AX7 (Clean Preamp)
- V2: JJ 12AX7 (Gain Preamp)
- V3: JJ 12AX7 (Tone-stack)
- V4: Sovtek 12AX7LPS (Reverb)
- V5: JJ 12AX7 (FX Loop Send and Return)
- V6: Sovtek 12AX7LPS (Phase Inverter)
- V7 - V10: EL34 output tubes

Bias Adjustment

Your CITIZEN GAIN comes from the factory biased for EL34 tubes with an idle current draw of 28ma. Bias adjustments are not intended to be user-serviceable. Attempting to adjust the bias yourself will expose you to very dangerous high-voltage electricity that can kill you. Special test equipment and knowledge of amp circuits and tubes are required to perform this function. **DO NOT ATTEMPT TO DO THIS YOURSELF.**

Tube Replacement

WE RECOMMEND TAKING YOUR AMPLIFIER TO A QUALIFIED TECHNICIAN FOR SERVICING YOUR TUBES. Make certain the amplifier is turned off and has been allowed ample time to cool down. Be very careful when you remove the tubes as they might still be very hot! Do not touch tube sockets with fingers! Even after turning your amp off and unplugging it from the power outlet there could be enough voltage stored in the capacitors to give you a lethal electrical shock.

WARNING:

- Do not remove the back panel.
- Do not attempt to check or replace tubes yourself. Refer to an authorized service center.
- Never touch the tubes while the amplifier is turned on or has recently been turned ON. You can severely burn your fingers and hands.

Operational Notes:

7-Pin Jack Wiring Diagram

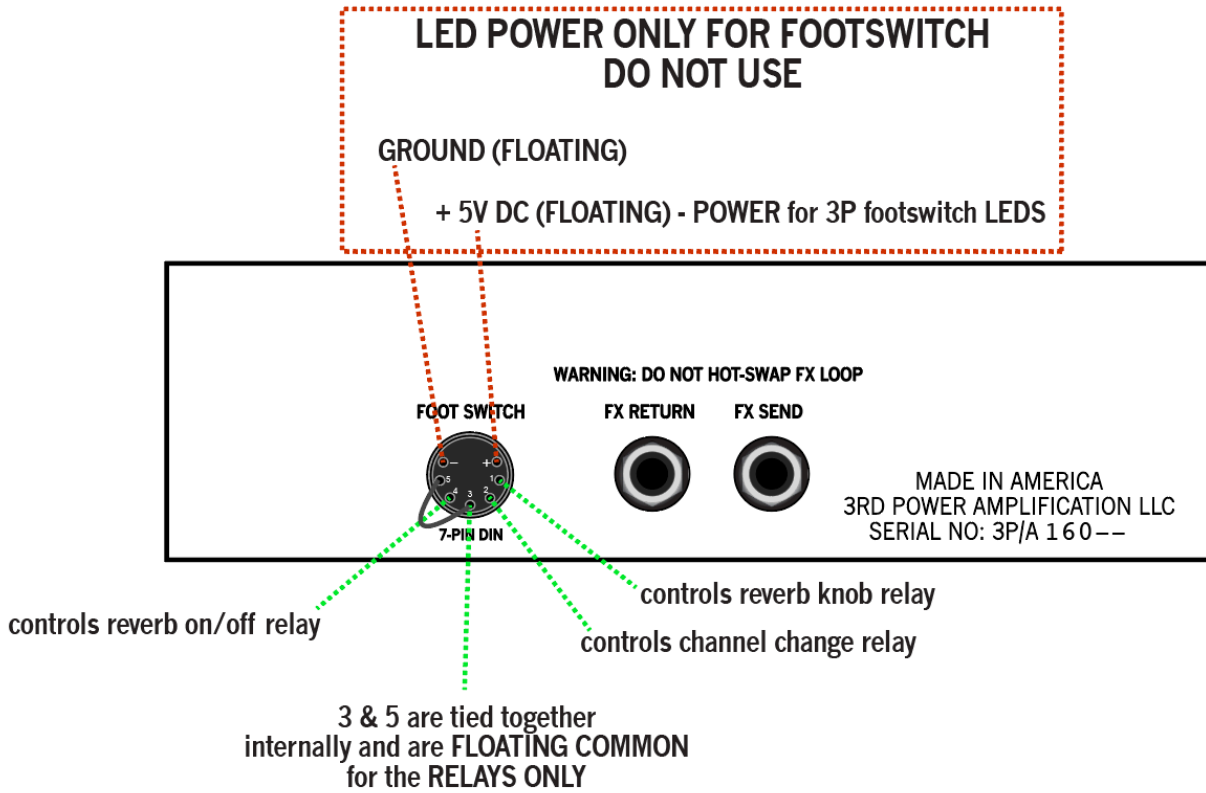

IN USE:
PIN 1 and 3 would select the reverb control
PIN 2 and 3 would select the channel operation
Pin 4 and 5 would select the reverb on/off

Operational Notes:

Example Gain Channel Settings:

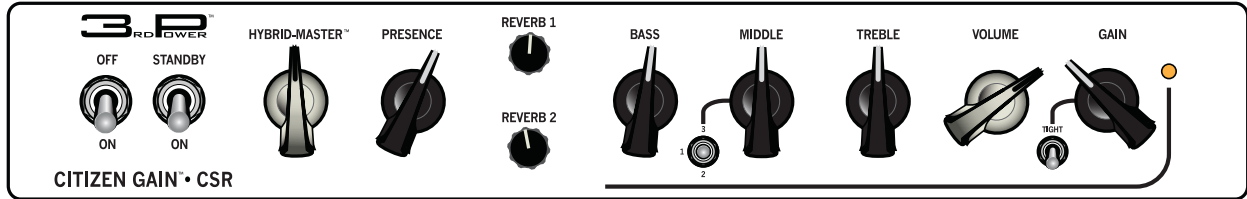

Are You Experienced?

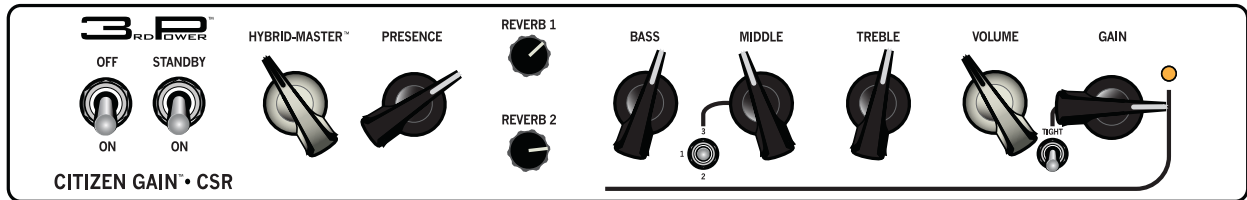

VH1

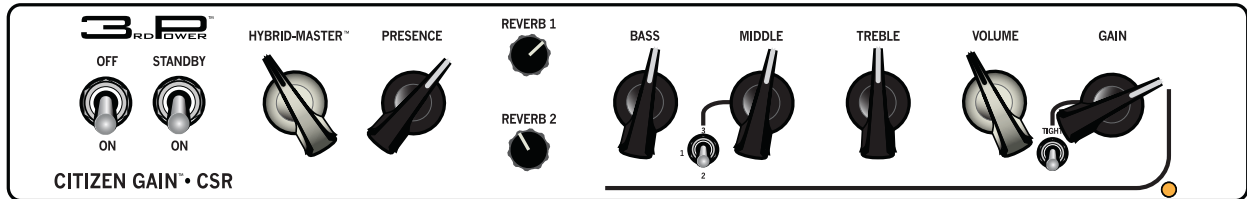

British Hard Rock/80s Hard Rock

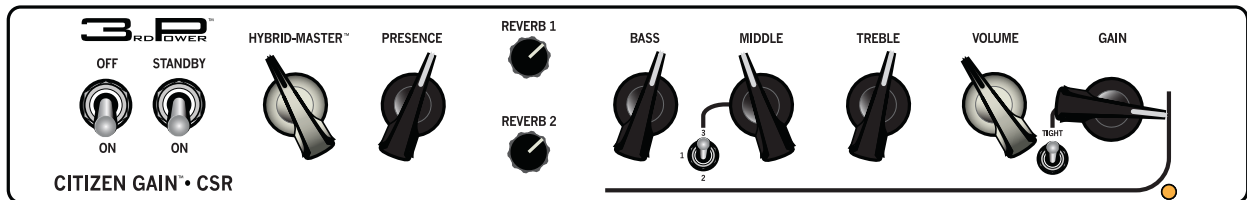

Late 80s/Early 90s/Modern Hard Rock

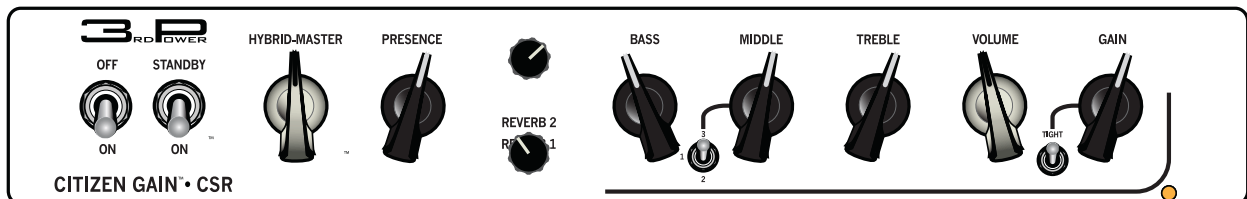

GnR

LIMITED WARRANTY

Thank you for choosing 3RD POWER Amplification. 3RD POWER takes great pride in producing high-quality tube amplifiers and speaker cabinets. Each product is thoroughly tested prior to shipment.

Your amplifier is warranted to the original purchaser to be free from defects in material and workmanship for a period of 33-1/3 years from the original date of purchase. An original sales receipt will establish coverage under this warranty. This warranty does not cover service or parts to repair damage caused by accident, neglect, abuse, normal wear, disaster, misuse, over-powering, negligence, inadequate packing or shipping procedures and service, repair or modifications to the product which have not been authorized by 3RD POWER. If this product is defective in materials or workmanship as warranted above, your sole remedy shall be repair or replacement as provided below.

Tubes: 3RD POWER warrants the original purchaser that the tubes used in the unit will be free from defects in material and workmanship for a period of 90 days from the original purchase date. A dated sales receipt will establish coverage under this warranty. This warranty is in lieu of all other expressed warranties. If tubes fail within the initial 90 day period your sole remedy shall be the replacement of tubes as provided below.

Return Procedures: In the unlikely event that a defect should occur, follow the procedure outlined below. Defective products must be shipped, together with proof of purchase, freight pre-paid and insured directly to 3RD POWER. A Return Authorization Number must be obtained prior to shipping the product. Contact 3RD POWER to obtain this RA number. Products must be shipped in their original packaging or equivalent. IN any case, the risk of loss or damage in transit is borne by the purchaser. The RA number must appear in large print directly below the shipping address. Always include a brief description of the defect, along with your correct return address and telephone number.

When calling to inquire about a returned product, always refer to the RA number. If 3RD POWER determines that the unit was defective in materials or workmanship at any time during the warranty period, 3RD POWER has the option of repairing or replacing the product at no additional charge, except as set forth below. All replaced parts become property of 3RD POWER. Products replaced or repaired under this warranty will be returned via ground shipping within the United States, freight prepaid. 3RD POWER is not responsible for costs associated with expedited shipping, either to 3RD POWER or returned of the product to the customer.

Incidental or Consequential Damage: In no event will 3RD POWER be liable for any incidental or consequential damages arising out of the use or inability to use any 3RD POWER product, even if a 3RD POWER dealer has been advised of the possibility of such damages or any other claim by any other party. Some states do not allow the exclusion or limitation of consequential damages, so the above limitation and exclusion may not apply to you. This warranty gives you specific legal rights and you may also have other rights which may vary from state to state.

For your protection: Please complete and mail the Purchase Information Card within (10) ten days of the date of purchase so that we may contact you directly in the event a safety notification issued in the accordance with the 1972 Consumer Product Safety Act.

Customer Support: Our dedicated staff is ready to assist you should you have any questions with regard to your product. Please call: (615) 945-3393 (9:00 AM to 5:00 PM Monday through Friday, Central Standard Time).



3RD POWER Amplification LLC
1307 Jewel Street
Nashville, TN 37207
Phone: (615) 945-3393

Web Site
www.3rdPower.com